

# Sliding Door System

## Folding Door

Fortress Land Door Hardware

### Partition Folding Door 80kg per panel

Track, brackets & bottom tracks	
10400	Top Aluminum track (Available in 5m, 3m, & 2m)
10043	Sliding angle plate for wall fixing
10043M	Sliding joining bracket for wall-fixing
10044	Sliding bracket for top-fixing
10044M	Sliding joining bracket for top-fixing
1110	Bottom Track U Profile 30x30

Rollers Hanger & accessories 80kg per panel	
9542N	Intermediate hanger, mounted on a hinge (capacity 80kg per panel)
9542 EN	Offset end hanger (capacity 80kg per panel)
1106	Bottom guide on a hinge for U profile 30x30
1106 EL	Offset bottom guide for U-profile 30x30
1106 EL	Hinge 120x100x3mm, Screwing type, a Ø20mm axle

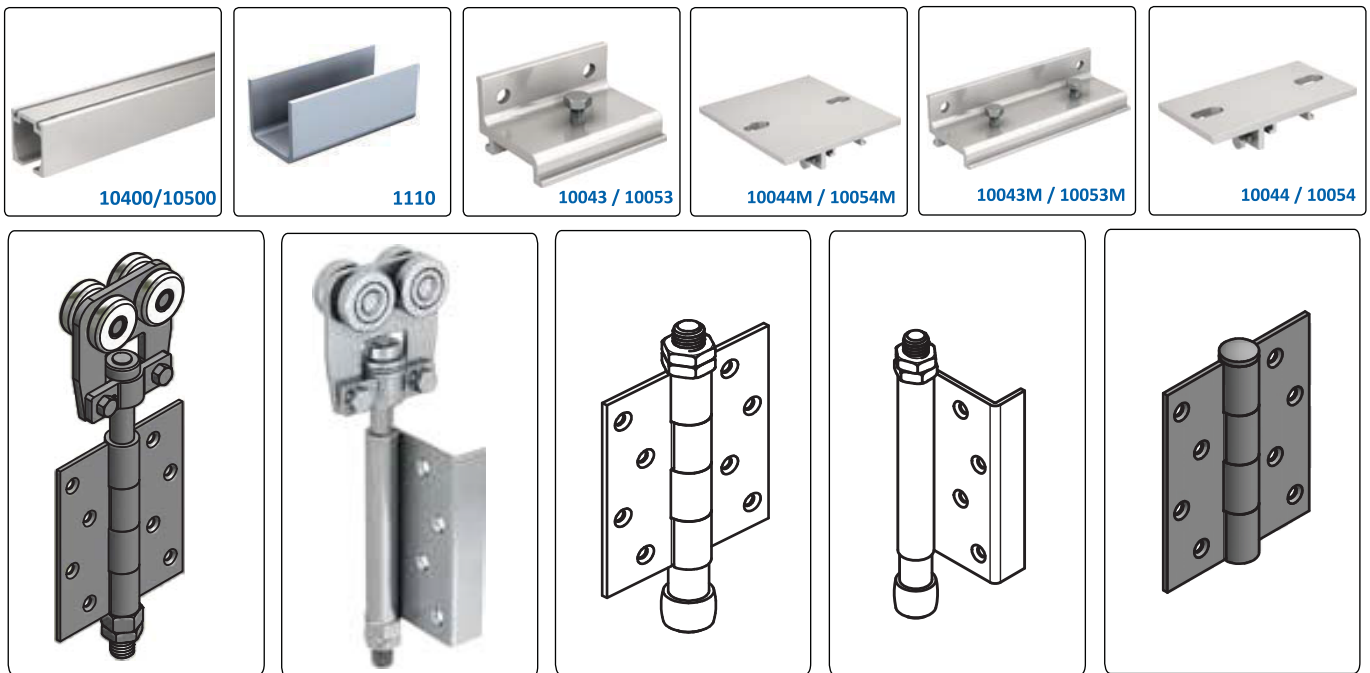

# Sliding Door System

Folding Door

Fortress Land Door Hardware

## Partition Folding Door 80kg per panel

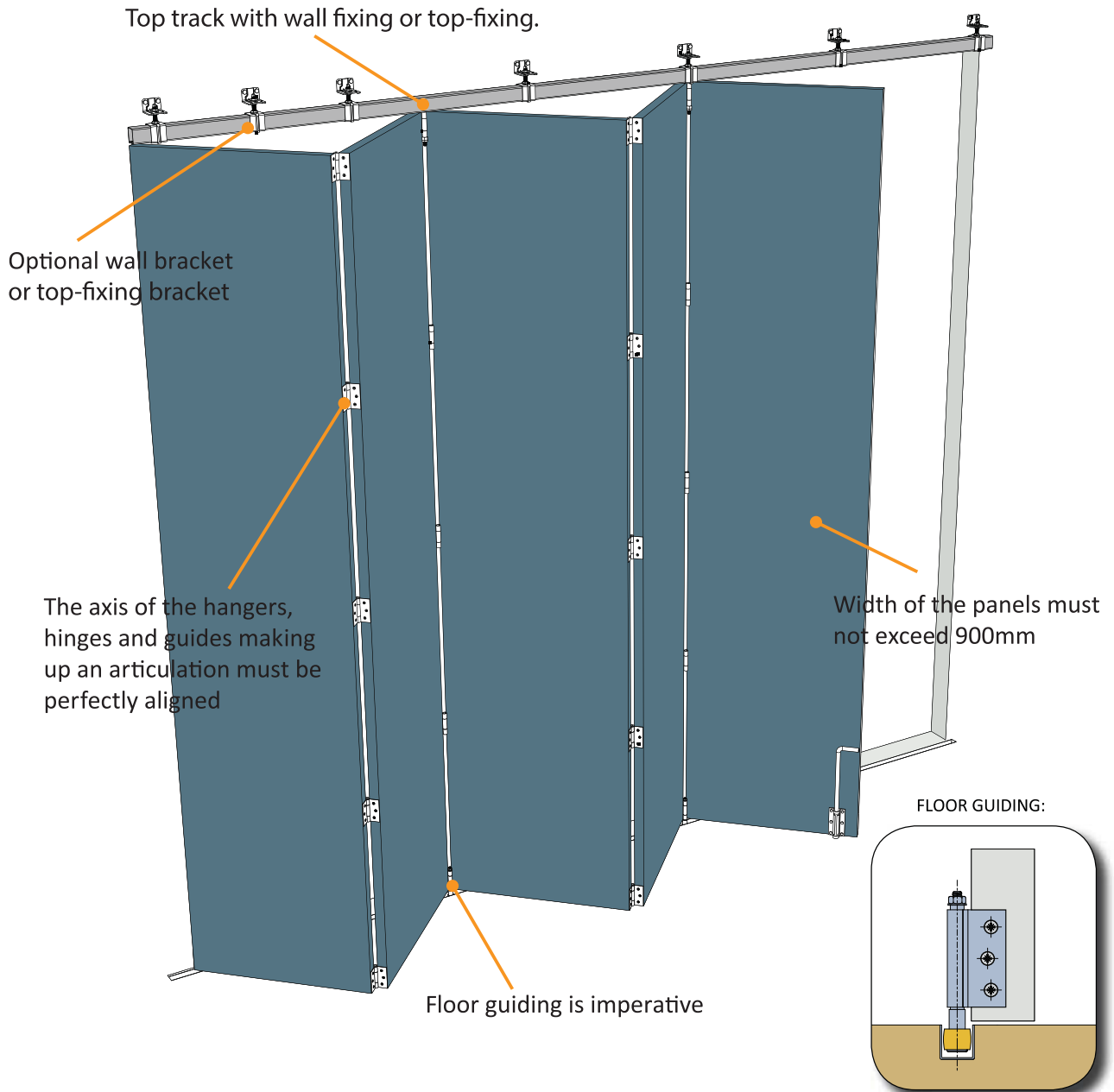

### EXAMPLES OF ASSEMBLY:

2 panels and 1 service door

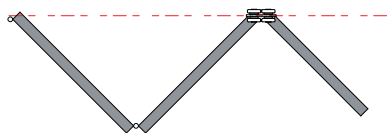

2 panels and 1 service door + 1 panel

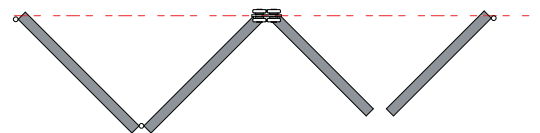

4 panels and 1 service door

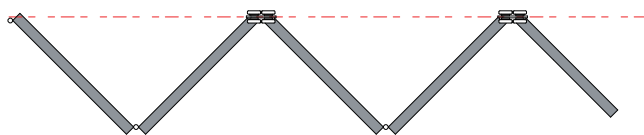

2 panels and 1 service door + 2 panels together

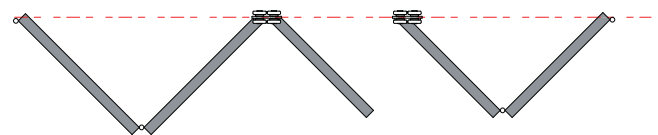

4 panels together

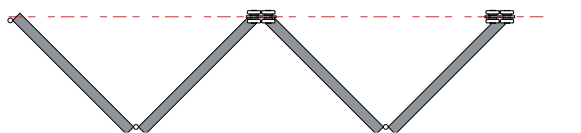

6 panels together

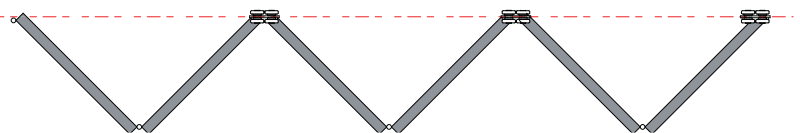

### Partition Folding Door 80kg per panel

#### USE OF END HANGERS

They must be fixed on to the end panels. The width of the end panels must be equal to the width of the other panels, increased by the G dimension.

Item N r	G
9542 EN	

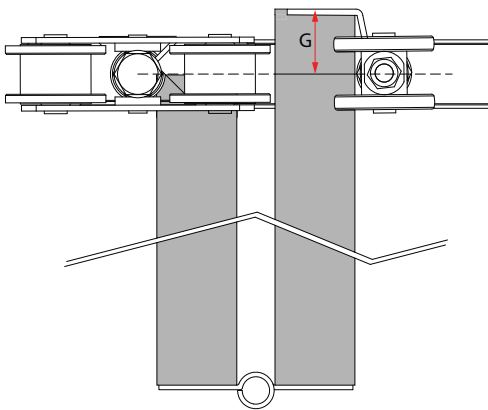

#### CROSS SECTION, TOP

Folding door with 4 panels and a swinging panel, folding on one side only. This top view of a set of panels shows more precisely the use of the items.

The swinging panel can be blocked by a bar (opening from inside only)

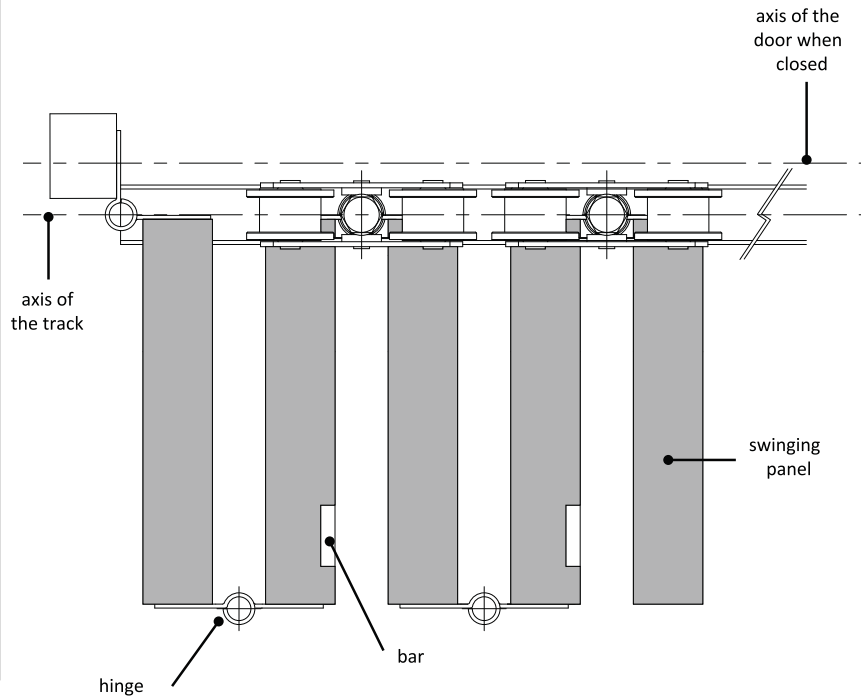

See our assembly recommendations on p. 26